

MDI SYSTEM 3[®] SAFETY PRODUCTS



***Signfaces
Sign Stands
Safety Apparel
Reference Guides
Training Programs
And More!***



Traffic Control Products
1-800-521-6776
www.mditrafficcontrol.com



At MDI, we know how important safety, protection, and visibility are to your work zone crews and equipment. With this in mind, we are proud to offer our customers a wide selection of high-quality, state-of-the-art, cost-effective work zone signage solutions. As an innovator in the industry, MDI is dedicated to continuously developing new improvements and

innovations to increase quality, longevity, and performance of our product line. We will assist you in selecting products to safeguard your work zones and crews. We value your business and promise to provide prompt and knowledgeable customer service, in-stock inventory, and reliable on-time delivery.

Contents

SIGNFACES

◆ DuraLatch® Signfaces	3
◆ Standard Signface Legends	4-5
◆ Changeable Signface Legends / Overlay Patches	6
◆ Crossbracing / Complete Signs	7

SIGN STAND SYSTEMS

◆ MDI System3®	8-9
----------------	-----

REFERENCE GUIDES

◆ Temporary Work Zone Guidelines	10
----------------------------------	----

TRAINING PROGRAMS

◆ On-Site Safety Education Seminars	10
-------------------------------------	----

SAFETY APPAREL

◆ Vests / T-Shirts	11
--------------------	----

ACCESSORIES

◆ Brackets, Stop / Slow Paddles, Storage, Flags	12-13
---	-------

SPECIFICATIONS

◆ MDI Sign Stand Selection Guide	14
◆ Signface / Sign Stand Compatibility Guide	14
◆ MDI Sign Stand Footprints	14

HOW TO ORDER

◆ MDI Makes it Easy to Order	15
------------------------------	----



Experience the
DuraLatch®
difference.
Engineered for
Performance.

DuraLatch®
roll-up signfaces
are backed by a
**2-YEAR
WARRANTY**
against defects in
workmanship, parts
and materials.

At MDI, innovation is number one. That's why our staff of qualified design engineers remain dedicated to reaching beyond the standard approach to product design with inventive solutions for all of your work zone signage needs.

The versatile DuraLatch® signface is the only self-adjusting roll-up signface available. Constructed of pliable EPDM rubber for greater flexibility, the DuraLatch® signface expands and contracts as needed -- allowing for more give-and-take in varying weather conditions. And, with less stress to the signface, you'll enjoy longer product life. That's a savings to you. It's so innovative and unique that it's patented.



- ◆ Keeps signface taut and readable because the latches continuously compensate for thermal expansion and contraction.
- ◆ Absorbs stress caused by gusting winds and passing vehicles.
- ◆ Will not disengage in backwinds like corner pocket signfaces.
- ◆ It's quick and easy to set up. The straps simply wrap around the crossbracing and snap into solid tip posts. Bending of crossbrace is not required as in corner pocket signfaces.
- ◆ Crossbracing is interchangeable. You don't have to buy crossbraces for each signface.
- ◆ The DuraLatch® signface attaches to the crossbracing with high-strength EPDM rubber latches.



Quick & easy setup –
Simply wrap DuraLatch®
strap around the crossbracing
and snap onto solid-tip posts.
Bending of crossbrace not
required like corner
pocket signfaces.



Standard Signface Legends

Standard Signface Legends



Designed for rugged performance and pay-back at an economical price.

To insure that you receive the correct material for your chosen signface, simply fill in the blanks ____- before the part number with the appropriate material prefix as listed below:

DuraLatch® Signface Material Prefixes

- DF** 3M™ Scotchlite™ Reflective Material / Fluorescent
- DFM** Marathon Fluorescence™
- DF3** 3M™ Scotchlite™ Reflective Material / Diamond Grade
- DNR** Non-Reflective



DuraLatch® signfaces and cross-bracing are sold separately. See page 7 for crossbracing options.

- | | | |
|--|--|--|
| <p>A FLAGGER (paddle symbol)
36" ____-05681
48" ____-05682</p> <p>B MERGE RIGHT (symbol)
36" ____-04104
48" ____-04105</p> <p>C SHOULDER WORK AHEAD
36" ____-04201
48" ____-04202</p> <p>D WORK AREA AHEAD
36" ____-03644
48" ____-03645</p> | <p>E WORKERS AHEAD
36" ____-03989
48" ____-04091</p> <p>F FLAGGER (flag symbol)
36" ____-03642
48" ____-03643</p> <p>G PREPARE TO STOP
36" ____-03655
48" ____-03656</p> <p>H UTILITY WORK AHEAD
36" ____-04203
48" ____-04204</p> | <p>I MOWING AHEAD
36" ____-04925
48" ____-04926</p> <p>J FRESH OIL
36" ____-07462
48" ____-09438</p> <p>K MERGE LEFT (symbol)
36" ____-04102
48" ____-04103</p> <p>L ONE LANE ROAD AHEAD
36" ____-03649
48" ____-03650</p> |
|--|--|--|





M WORKER (symbol)
36" ____-03640
48" ____-03641

N SURVEY CREW
36" ____-04092
48" ____-04093

O FLAGGER AHEAD
36" ____-04094
48" ____-04095

P SHOULDER WORK
36" ____-04196
48" ____-04197

Q BE PREPARED TO STOP
36" ____-03765
48" ____-03766

R ROAD WORK AHEAD
36" ____-04096
48" ____-04097

S ROAD CLOSED AHEAD
36" ____-04106
48" ____-04107

T SIGNAL WORK AHEAD
36" ____-04409
48" ____-04405

U LOOSE GRAVEL
36" ____-10192
48" ____-09395

V STOP (36" only)
36" DL-04110



DuraLatch® signfaces and cross-bracing are sold separately. See page 7 for crossbracing options.

Changeable Signface Legends / Overlay Patches

Changeable

Signface Legends

3M™ Scotchlite™ Hook & Loop strips make legend changes fast and easy.



UTILITY WORK AHEAD
 36" ____-03659
 48" ____-03660
 P1 P2 P3



ROAD WORK AHEAD
 36" ____-04205
 48" ____-04206
 P4



ROAD WORK AHEAD
 36" ____-07034
 48" ____-07035
 P1 P2 P3



RIGHT LANE CLOSED AHEAD
 36" ____-03657
 48" ____-03658
 P5 P6



RIGHT LANE CLOSED AHEAD
 36" ____-04991
 48" ____-04912
 P5 P6 over RIGHT
 P7 P8 P9 over AHEAD

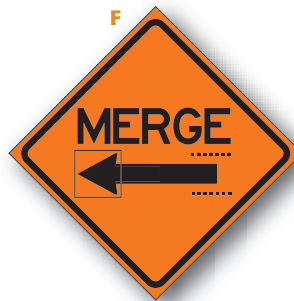

MERGE
 (overlay patch included)
 36" ____-04100
 48" ____-04101



TRANSITION SYMBOL
 (overlay patch included)
 36" ____-09469
 48" ____-07043

To insure that you receive the correct material for your chosen signface, simply fill in the blanks ____- before the part number with the appropriate material prefix as listed at right:

DuraLatch® Signface Material Prefixes

DF 3M™ Scotchlite™ Reflective Material / Fluorescent
DF3 3M™ Scotchlite™ Reflective Material / Diamond Grade

DFM Marathon Fluorescence™
DNR Non-Reflective



DuraLatch® signfaces and crossbracing are sold separately. See page 7 for crossbracing options.

Overlay Patches

Overlay Patch Material Prefixes

PF 3M™ Scotchlite™ Reflective Material / Fluorescent
PF3 3M™ Scotchlite™ Reflective Material / Diamond Grade

PFM Marathon Fluorescence™
PNR Non-Reflective

P1 Two-sided
 500 FT
 36" ____-03463
 48" ____-05231

P2 Two-sided
 1000 FT 1500 FT
 36" ____-03464
 48" ____-05232

P3 Two-sided
 1/2 MILE 1 MILE
 36" ____-04370
 48" ____-05233

P4 SHOULDER
 SHOULDER
 36" ____-03952
 48" ____-03953

P5 LEFT
 LEFT
 36" ____-04408
 48" ____-04409

P6 Two-sided
 LEFT CENTER
 36" ____-03931
 48" ____-03930

P7 Two-sided
 500 FT
 36" ____-28376
 48" ____-05508

P8 Two-sided
 1000 FT 1500 FT
 36" ____-28377
 48" ____-05509

P9 Two-sided
 1/2 MILE 1 MILE
 36" ____-28378
 48" ____-05922



Durable

Interchangeable

Crossbracing

1 1/4" wide fiberglass crossbracing for diamond-shaped DuraLatch® roll-up signfaces.

Crossbracing is interchangeable with same size DuraLatch® signfaces. Crossbracing available in three styles for 36" or 48" signfaces.

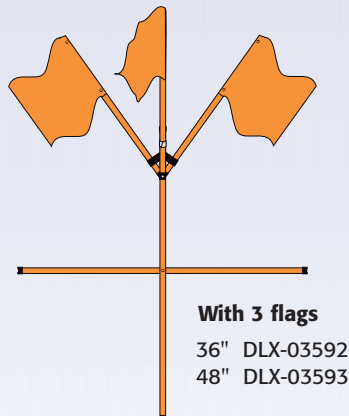
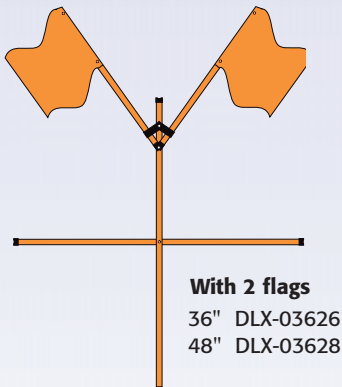
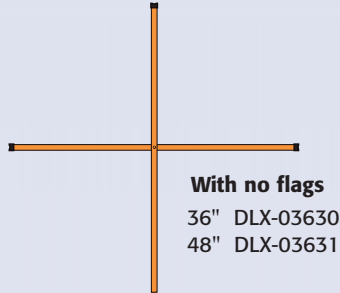

CROSSBRACING

36" crossbracing:
vertical = 1/4" thick
horizontal = 3/16" thick

48" crossbracing:
vertical = 3/8" thick
horizontal = 3/16" thick



Complete Signs

Crossbracing included (no flags)



24" x 48" (Points left or right)

REVERSIBLE ARROW
___-05827



24" x 48"

END UTILITY WORK
___-03623



24" x 48"

END ROAD WORK
___-05079



30" x 30"

END WORK AREA
___-03597

MDI's Answer to Quick Set-up of Work Zones

MDI System 3[®] sign stands are specially engineered for portability, ease of handling, and reliable performance in temporary work zones.

- ◆ Quick and easy one-person set-up without tools.
- ◆ Kick-release/telescoping legs simplify set-up and handling.
- ◆ Dual-spring base for strong initial tension resists twisting and turning of sign in high wind gusts.
- ◆ Adjustable legs for stability on curbs or uneven terrain.
- ◆ Easy handling and convenient storage. Occupies only 1-cubic foot of storage space when folded.
- ◆ Designed for use with long-lasting MDI DuraLatch[®] signfaces.
- ◆ 4814[®]HDK's larger footprint provides greater wind resistance.



The patented design allows the worker to remain upright, increasing traffic visibility.

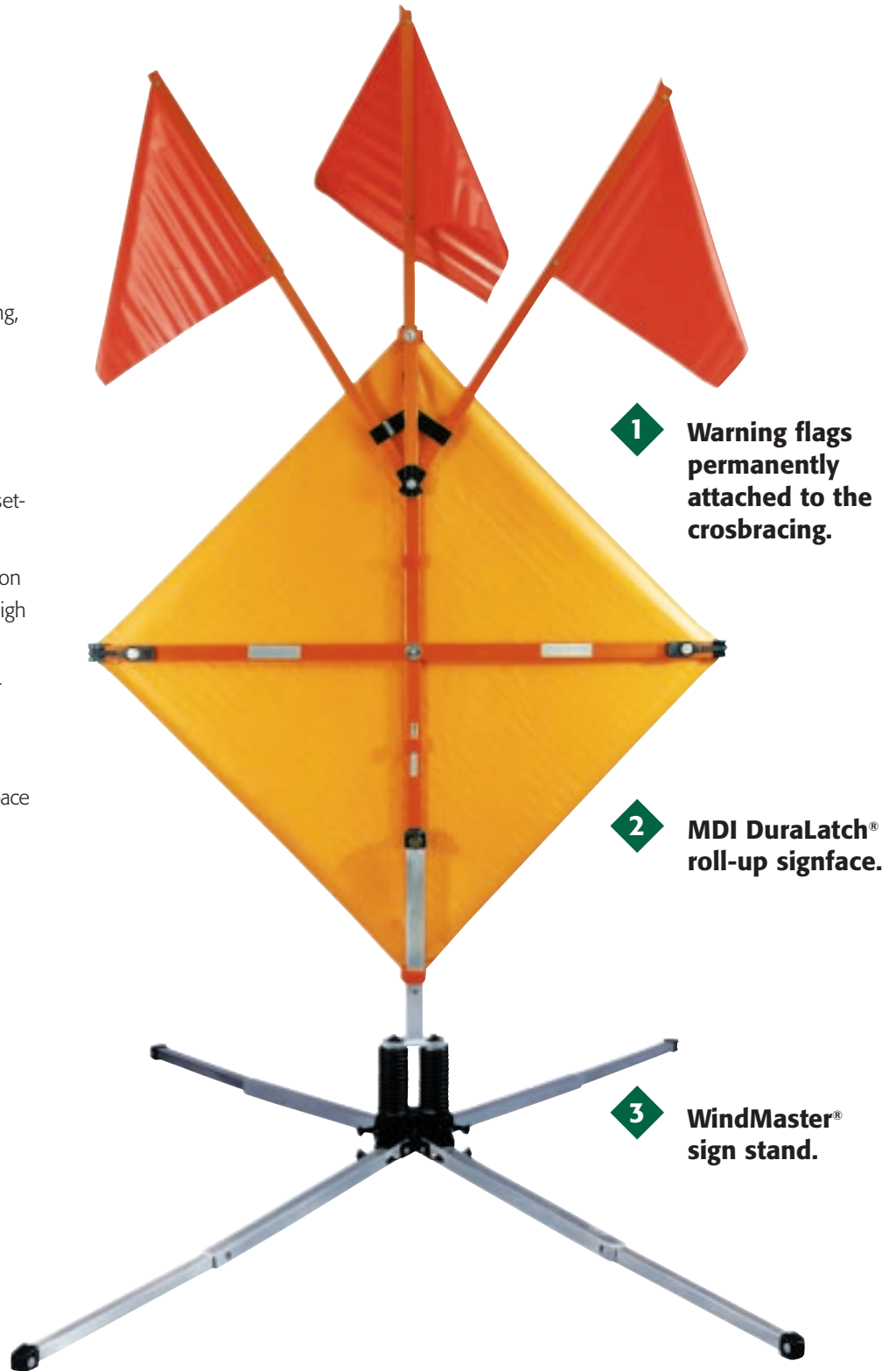

MDI's Original
WindMaster[®]
Sign Stands



Sign stands have kick-release legs for easy deployment.



Adjustable legs for stability on curbs and uneven terrain.



Model Number	Deployed Height ¹	Sign Height ²	Folded Dimensions (H x W x D)	Weight (w/o Brackets)	MDI DuraLatch [®] Roll-up Signfaces	Rigid Signfaces	WindMaster [®] Springs
4814 [®] DLK	6'10½"	1'2½"	2'1" x 6¼" x 6¼"	20 lbs.	◆	–	Dual
4814 [®] HDK	6'10½"	1'2½"	2½' x 6¼" x 6¼"	22 lbs.	◆	–	Dual

¹To top of 48" signface without flags

²Distance of 48" signface from ground

Reference Guides

Convenient Pocket-sized Reference Guide Assists in Safeguarding Temporary Work Zones

The Work Zone Reference Guide is designed to withstand rugged outdoor conditions. Laminated pages protect against moisture and staining; configured to fit most pockets (3-3/8" x 7-7/8"); durable plastic spiral binding.



CONTENTS:

- ◆ General Information
- ◆ Devices
- ◆ Flagging Guidelines
- ◆ Reference Charts
- ◆ Typical Work Areas

**ADVANCE
WARNING
SAVES LIVES!**

**QUANTITY DISCOUNTS
AVAILABLE**

Typical Work Areas TWA-10

Left Lane Closure - Far Side of Intersection

See Chart A on page 36 for Buffer Length, Chart B on page 36 for Sign Spacing and Chart C on page 37 for Taper Length and Channelizer Quantity

- For intersection approaches reduced to a single lane, left turning movements may be prohibited to maintain capacity for through traffic.
- Common procedure is to close on the near side of the intersection any lane that is not closed through the intersection.
- If a walk extends across the crosswalk, the crosswalk must be closed.
- Flashing warning lights and/or flags may be used to call attention to the advance warning signs.

Reference Charts

Chart C
Suggested Taper Length and Channelizer Quantity

Speed mph	Width of Lane			
	Minimum Taper Length (Minimum # of channelizers)			
	8'	10'	12'	14'
30	120' (5)	150' (6)	180' (7)	210' (8)
35	163' (5)	204' (6)	245' (8)	286' (9)
40	213' (6)	267' (7)	320' (8)	373' (9)
45	360' (8)	450' (11)	540' (13)	630' (15)
50	400' (9)	500' (11)	600' (13)	700' (15)
55	440' (9)	550' (11)	660' (13)	770' (15)
60	480' (9)	600' (11)	720' (13)	840' (15)
65	520' (9)	650' (11)	780' (13)	910' (15)

Taper Type (L = minimum length of taper)
Merge = L
Shift = 1/2 L
Shoulder = 1/3 L
Downstream = 100' Min.
One-Lane / Two-Way with flagger = 100' Max.

For lengths not shown at left:
Minimum taper length (L) for roadways
40 mph or less: L = WS² / 60
45 mph or more: L = WS

Local regulations may vary. © Copyright 2003 MDI Traffic Control Products. All rights reserved. RG-1000 Published 8/03 37

WORK ZONE TRAFFIC CONTROL REFERENCE GUIDE

Color-coded easy-reference format includes concise information and illustrated deployment diagrams.

RG-1000

Training Programs

SAFETY TRAINING PROGRAMS

MDI Traffic Control Products, the industry leader in safety products and advance warning systems for work zone crews, is a highly proactive, long-term supporter of safety needs.

MDI now provides specialized on-site training programs, taught by dedicated safety professionals.

CONTACT

Glenda Bleau, MDI Product Manager
800-521-6776
gbleau@mdiworldwide.com

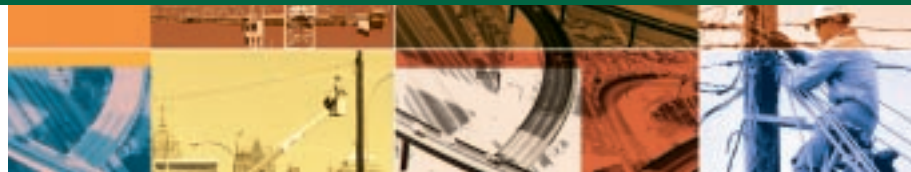

PROGRAMS INCLUDE:

- ◆ Temporary Traffic Control
- ◆ Confined Space Entry
- ◆ Trench Compliance & Competent Person
- ◆ Fall Protection & Prevention
- ◆ Technical Rescue
 - Vertical
 - Confined Space
 - Trench
- ◆ Fire Brigade
 - Fire Extinguisher Skills
 - Live Fire Skills
 - SCBA Skills
- ◆ First Aid, CPR and AED

**LOOKING FOR A PROGRAM
NOT LISTED ABOVE?**

**PLEASE INQUIRE. OTHER
PROGRAMS ARE AVAILABLE.**



Increased visibility saves lives

All sizes...same price!

No up-charge for larger sizes!



ECONOSTYLE MESH VEST

Day-glow orange mesh vest with 3/4" silver reflective bands. VELCRO® closure. Conforms to MUTCD minimums. Sizes: M, L, XL, 2X, 3X, 4X

◆ **V9801-O**



ECONOSTYLE PLUS MESH VEST

Day-glow lime mesh vest with orange 2" twin trim reflective bands. VELCRO closure. Conforms to MUTCD minimums. Sizes: M, L, XL, 2X, 3X, 4X

◆ **V9802-L**



ANSI CLASS 2 T-SHIRT

Ideal for warm weather conditions requiring ANSI Class 2 compliance. Transports moisture away from the body and dries faster than cotton for maximum comfort and breathability. Sizes: M, L, XL, 2X, 3X

◆ **TS9810-L**
◆ **TS9811-O**



ANSI CLASS 2 BREATHABLE VEST

Day-glow lime breathable vest with 2" silver reflective bands, one inside and one outside pocket, extra large arm holes and nylon zipper closure for ANSI Class 2 compliance. Sizes: M, L, XL, 2X, 3X, 4X

◆ **V9890-L**



ANSI CLASS 2 VEST - SINGLE BAND

2" silver reflective bands, extra large arm holes and VELCRO closure for ANSI Class 2 compliance. Sizes: M, L, XL, 2X, 3X, 4X

◆ **V9820-L**



ANSI CLASS 2 VEST - DOUBLE BAND

Double 2" silver reflective bands, extra large arm holes and VELCRO closure for ANSI Class 2 compliance. Sizes: M, L, XL, 2X, 3X, 4X

◆ **V9821-L**



ANSI CLASS 3 SURVEYOR'S VEST

Double 2" reflective bands, extra large arm holes, 3 inside pockets and VELCRO closure for ANSI Class 3 compliance. Sizes: M, L, XL, 2X, 3X, 4X

◆ **VS3000-L**
◆ **VS3001-O**



ANSI CLASS 2 FIRE RETARDANT UTILITY VEST

Fire retardant vest with double 2" silver reflective bands, extra large arm holes and nylon zipper closure for ANSI Class 2 compliance. Sizes: M, L, XL, 2X, 3X, 4X

◆ **VS3020-L**
◆ **VS3021-O**



ANSI CLASS 2 TWIN TRIM VEST

Effective in increasing visibility. 4" twin trim with 2" silver reflective bands and VELCRO closure. Cell phone and storage pockets. Minnesota OSHA compliant. Sizes: M, L, XL, 2X, 3X

◆ **V9830-L**
◆ **V9831-O**



ANSI CLASS 2 TWIN TRIM TEAR AWAY VEST

Tear away vest effective in increasing visibility. 4" twin trim with 2" silver reflective bands, VELCRO side and shoulder seams and VELCRO front closure. Cell phone pocket and storage pockets. Minnesota OSHA compliant. Sizes: M, L, XL, 2X, 3X, 4X

◆ **V9832-L**
◆ **V9833-O**

BRACKETS, STORAGE, FLAGS, STOP / SLOW PADDLES

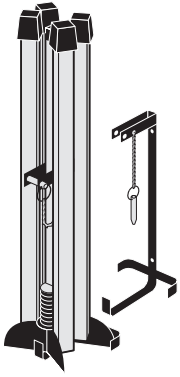

TRUCK MOUNT BRACKET

Use to lock stands in place on inside or outside of trucks.
For use with: 4814®DLK • 4814®HDK

SA-03322

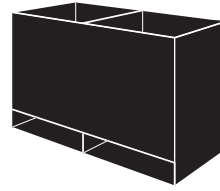

STAINLESS STEEL SIGN STAND STORAGE BOX

Stainless steel box.
Dimensions: 14" W x 7" D x 10" H.
Capacity: two sign stands.
For use with: 4814®DLK • 4814®HDK

SA-04901



ROLL-UP SIGNFACE STORAGE BAG

Heavy-duty nylon bag with handles and hook & loop fasteners.
For use with MDI roll-up signfaces.

Capacity: **SA-07195** (1) 36" signface

SA-04195 (1) 48" signface

SA-07196 (2) 36" signfaces

SA-03942 (2) 48" signfaces

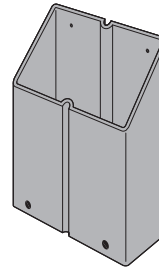

SIGN STAND STORAGE BOX

High-density polyethylene container for installation on inside or outside of trucks.

Dimensions: 18" W x 8" D x 24" H.

Capacity: two sign stands.

For use with: 4814®DLK • 4814®HDK

SA-05440



SIGN STAND STORAGE BAG

Heavy-duty nylon bag with handles and hook & loop fasteners.
Capacity: one sign stand.

SA-04504 For 4814®DLK

SA-07201 For 4814®HDK

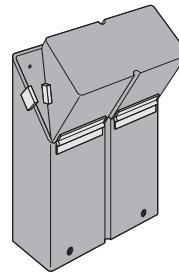

COVERED SIGN STAND STORAGE BOX

High-density polyethylene container for installation on inside or outside of trucks.

Dimensions: 18" W x 8" D x 26" H.

Capacity: two sign stands.

For use with: 4814®DLK

SA-05441

BRACKETS, STORAGE, FLAGS, STOP / SLOW PADDLES

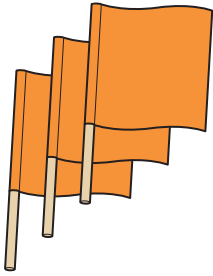

SET OF THREE WARNING FLAGS

Three fluorescent orange flags with integrated stays, on 30" long hardwood dowels.

SA-04581

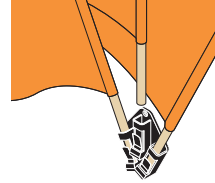

PLASTIC FLAG BRACKET

Locks wooden-dowel flags securely in place.

SA-10002



HIGH-LEVEL WARNING MAST

Telescoping mast allows sign stands to display three flags 8' in the air. Includes mast and three flags. For use with: 4814®DLK • 4814®HDK

SA-04496

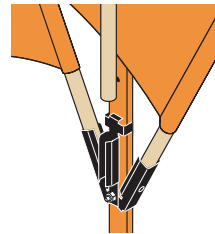

MDI COMPACT™ FLAG BRACKET KIT

Used to attach wooden dowel flags to the fiberglass crossbracing of roll-up signfaces. Includes flag bracket and installation hardware.

SA-28623

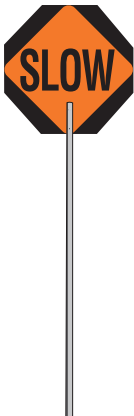

STOP / SLOW PADDLE

- 18RF** 18" reflective, 10" handle
- 24RF** 24" reflective, 5' handle
- 18NR** 18" non-reflective, 10" handle
- 24NR** 24" non-reflective, 5' handle

Sign Stand Specifications

MDI SIGN STAND SELECTION GUIDE

Model Number	Page #	Rigid & Roll-up Signfaces	Roll-up Signfaces Only	High-Level Warning	Weight of 25lbs or Less	Compact Storage	All Steel Construction	Steel/Aircraft Aluminum Alloy Construction	Sign Height
4814®DLK	9		◆		◆	◆		◆	14½"
4814®HDK	9		◆		◆	◆		◆	14½"

MDI SIGNFACE / SIGN STAND COMPATIBILITY GUIDE

Model Number	Page #	MDI DuraLatch® Roll-up Signface		Rigid Signface	
		36"	48"	36"	48"
4814®DLK	9	◆	◆		
4814®HDK	9	◆	◆		

MDI SIGN STAND FOOTPRINT

Model Number	Page #	Length A	Length B
4814®HDK	9	87"	60"
4814®DLK	9	71"	50"

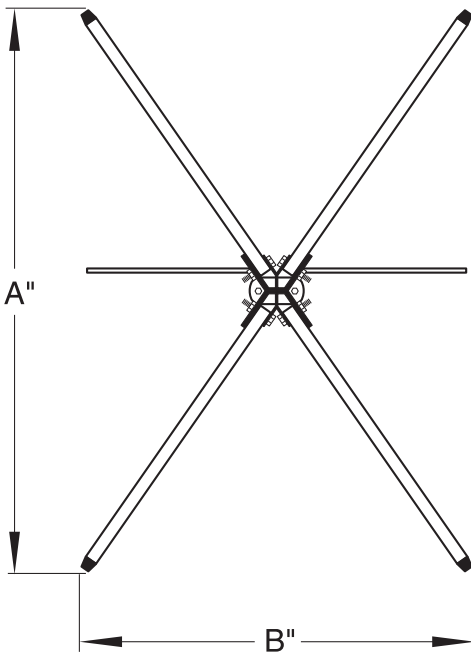

MDI MAKES IT EASY TO ORDER

3 easy ways to order

**Toll-Free:**

1-800-521-6776
(8:30 am - 5:00 pm EST,
Monday - Friday)

**Fax:**

1-248-488-5700

**Mail:**

Customer Service Department
MDI Traffic Control Products
38271 W. Twelve Mile Road
Farmington Hills, MI 48331

Have a question?



We invite you to place your order with our knowledgeable sales coordinators. We value your business and are ready to take your call at **1-800-521-6776**, or e-mail **tcpsales@mdiworldwide.com**.



MDI maintains and updates a database of all current state specification requirements to further assist your traffic control needs.

Thank you.

As a leader in the industry, MDI takes great pride in supplying the highest quality work zone signage products available. Thank you for choosing our product line. We welcome the opportunity to assist you in selecting the appropriate products for all your work zones.





*MDI can help you
meet your work zone
safety requirements*

MDI maintains and updates a database of all current state specification requirements to further assist your traffic control needs.

Within minutes, MDI's knowledgeable sales coordinators can research the requirements that apply to your work zone and provide the products to meet them. We value your business and are ready to take your call at **1-800-521-6776**, or e-mail **tcpsales@mdiworldwide.com**.



MDI Traffic Control Products
38271 W. Twelve Mile Road
Farmington Hills, MI 48331-3041
Toll Free: 1-800-521-6776
Fax: 248-488-5700
tcpsales@mdiworldwide.com
www.mditraficcontrol.com

BreakAway, CamLock, DuraLatch, MDI Compact, System 3, SteelMaster, TrafficMaster, WindMaster, 4812, 4814, 4818, 4860; MDI, logo design and globe; WindMaster, and logo spring design; are trademarks of Marketing Displays, Inc. 3M and Scotchlite are trademarks 3M company. SuperBright and Marathon Fluorescence are trademarks of Reflexite North America. VELCRO is a trademark of Velcro Industries B.V. Covered by one or more of the following U.S. patents: 1,242,321; 1,313,111; 1,389,946; 1,410,129; 1,765,908; 1,789,117; 1,789,118; 1,789,119; 1,789,120; 2,487,369; 2,604,241; 5,472,162; 5,829,178; 6,032,908; 6,056,250; 6,237,268; 6,237,883; 6,427,964; 6,560,906; 6,606,809. Foreign patents. Other domestic and foreign patents pending. © 2004. Marketing Displays, Inc. All rights reserved. Litho U.S.A.

DISTRIBUTED BY:

