

# WORKS BARRICADE TD2100 MODEL

NCHRP350 CRASH TEST CERTIFIED AND MEETS MUTCD STANDARDS



BARRICADES IN A-FRAME  
PARADE BARRIER APPLICATION



AVAILABLE WITH SAND  
BALLAST SYSTEM (SBS)

## FEATURES:

- Unique sand ballast system eliminates awkward sand bags and stabilizes the barricade in windy conditions.
- Lightweight features allow ease of handling.
- Injection molded leg design provides increased strength and prevents sagging in extreme heat.
- Panels are recessed to protect the reflective sheeting.
- Strong one piece design insures improved impact resistance.
- Completely stackable to reduce warehouse space.
- Molded clips holds 24" to 48" signs.
- Manufactured from specially formulated plastic compound, utilizing polymer protection and a UV stabilizer.
- Designed to yield upon impact to minimize vehicle damage.

## COLORS AVAILABLE:

The TD2100 Works Barricades are currently available in Fluorescent Orange or White. Three D Traffic Works can manufacture this product to your desired color.

## GENERAL INFORMATION:

*General information is listed on the reverse side. The measurements provided is intended only as a source of information. They are given without guarantee and is not classified as a warranty. A specification will be sent to you upon request.*



Another Innovative Product From The Works™



**Three D  
Traffic Works, Inc.**

**MADE IN  
USA**



**TD2100 WORKS BARRICADE**  
**Type I & II All Plastic Barricades**  
**Available with Sand Ballast System (SBS)**

- **Folded Thickness: 2.5"**  
**Height: 45.5"**  
**Width: 24.00"**  
**Weight: 15 lbs (without SBS) 23 lbs (with SBS)**
- **Optional Sand Ballast System (SBS) attach to sand bag rails; holds sand or pea gravel adding up to 8 lbs. of ballast**
- **Light bolt recessed in hinge for anti-theft attachment.**
- **Colors: Fluorescent Orange and White.**
- **Material: UV Stabilized Polymer Alloy with a Cold Weather Protection Package.**

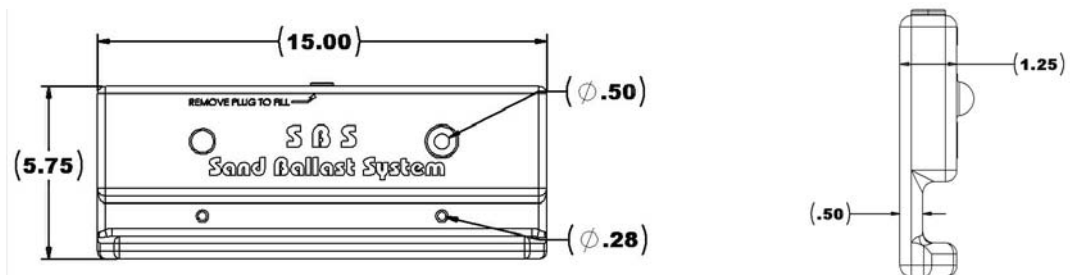
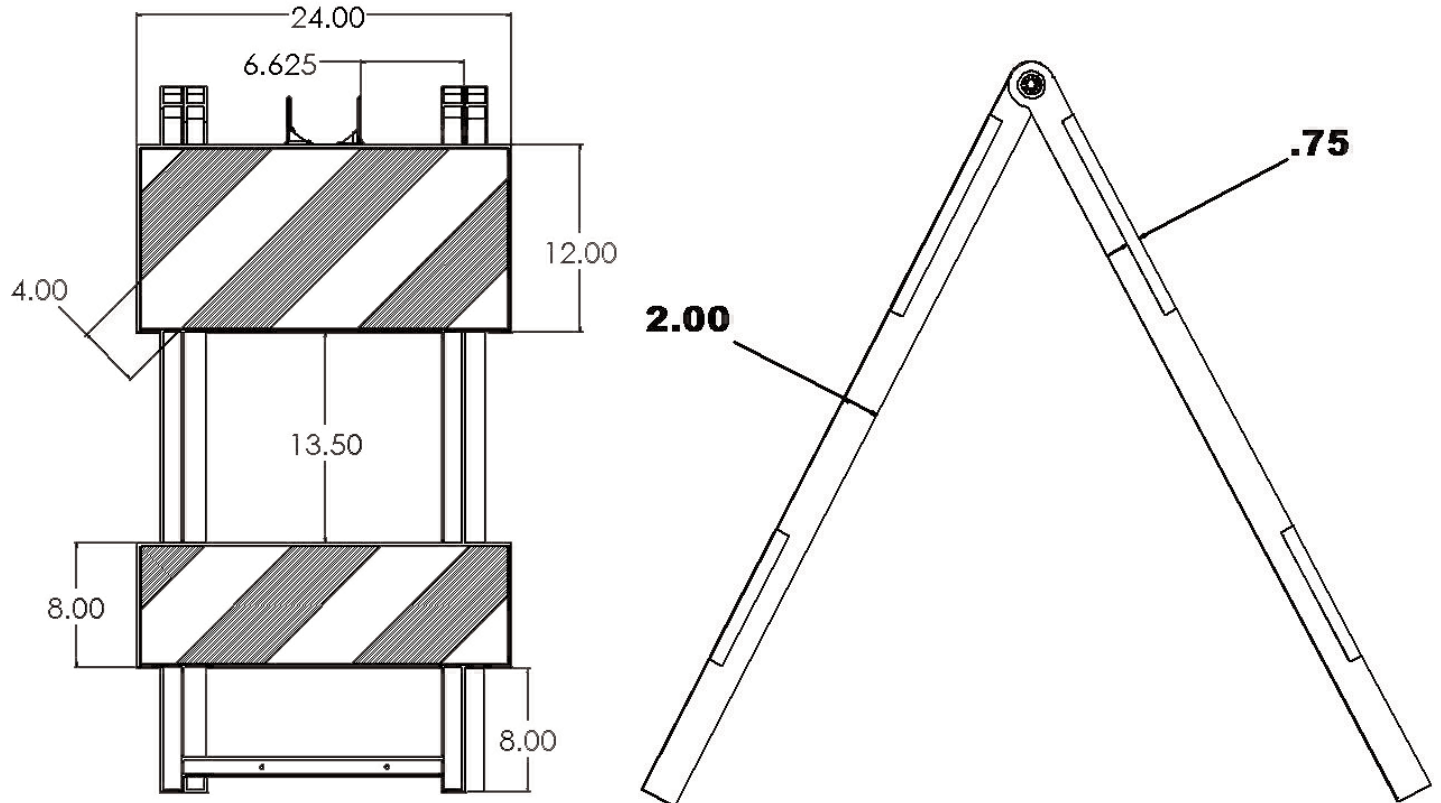

**SBS SAND BALLAST SYSTEM**