

# A-FRAME BARRICADE PARADE BARRICADE TD3000 MODEL

NCHRP350 CERTIFIED AND MEETS MUTCD STANDARDS



## FEATURES:

- Lightweight features allows for ease of handling.
- Withstands the strongest of impacts.
- Manufactured from a specially formulated plastic compound utilizing polymer protection UV stabilizer.
- Available with TD4000 (1"x8" and 2"x8") extruded plastic boards in any length desired.
- Legs angle in "Parade Application" for greater stability.
- Top rail is 36.5" above ground to conform to MUTCD standards.
- Can be used as a Type I or Type II barricade or a sign stand.
- Light attachment on top of the barricade.

## COLORS AVAILABLE:

The TD3000 Works Parade Barricades are currently available in white. Three D Traffic Works can manufacture this product to your desired color.

## GENERAL INFORMATION:

*General information is listed on the reverse side. The measurements provided is intended only as a source of information. They are given without guarantee and is not classified as a warranty. A specification will be sent to you upon request.*

Another Innovative Product From The Works™



**Three D  
Traffic Works, Inc.**

**MADE IN  
USA**



**TD3000 A-Frame Barricade  
 Specifications**

- **A Frame Leg Dimensions:**  
 Height: 1.8 Inches  
 Width: 30 Inches  
 Length: 42 Inches  
 Weight: 7 lbs
- **Each Hinge contains polymer pin for connecting two legs together for Type I or II barricade application.**
- **Each Hinge contains polymer pin for connecting two legs together for Type I or II barricade application.**
- **Parade barricade application consists of two TD3000 A-Frame legs and TD4000 Series plastic boards**
- **Boards available in 4 Foot through 20 Foot Lengths.**
- **Molded warning light hole allows attachment to A-Frame leg**
- **Color: White**
- **Material: UV Stabilized Polymer Ally with a Cold Weather Protection Package.**

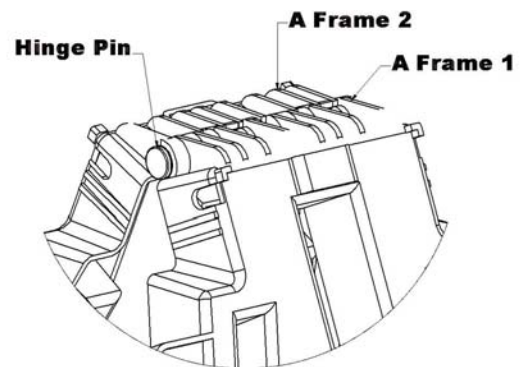
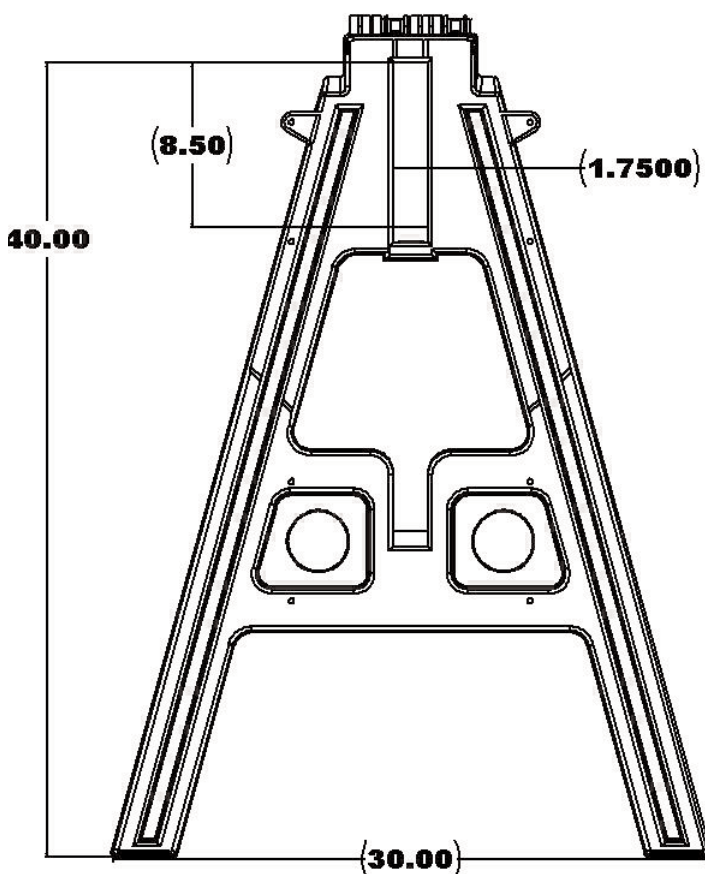

**A-Frame Hinge Assembly**

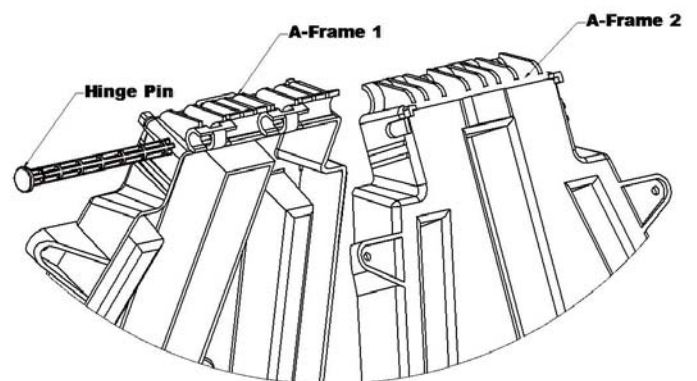

**A-Frame Hinge Assembly  
 Exploded View**